

**REAR VIEW**  
(SHOWING SEPARATION OF ELBOW)  
NO SCALE

REDUCED PRESSURE ZONE DEVICE BY FEBCO MODEL 825Y. TO BE MOUNTED IN SETTER AS SUPPLIED BY WATER DISTRICT.

SEPARATION BETWEEN

**NOTE**  
REDUCED PRESSURE ZONE DEVICE (RPZ), WATER METER & SETTER (INCL. BALL VALVES) ARE TO BE PURCHASED FROM THE WATER DISTRICT

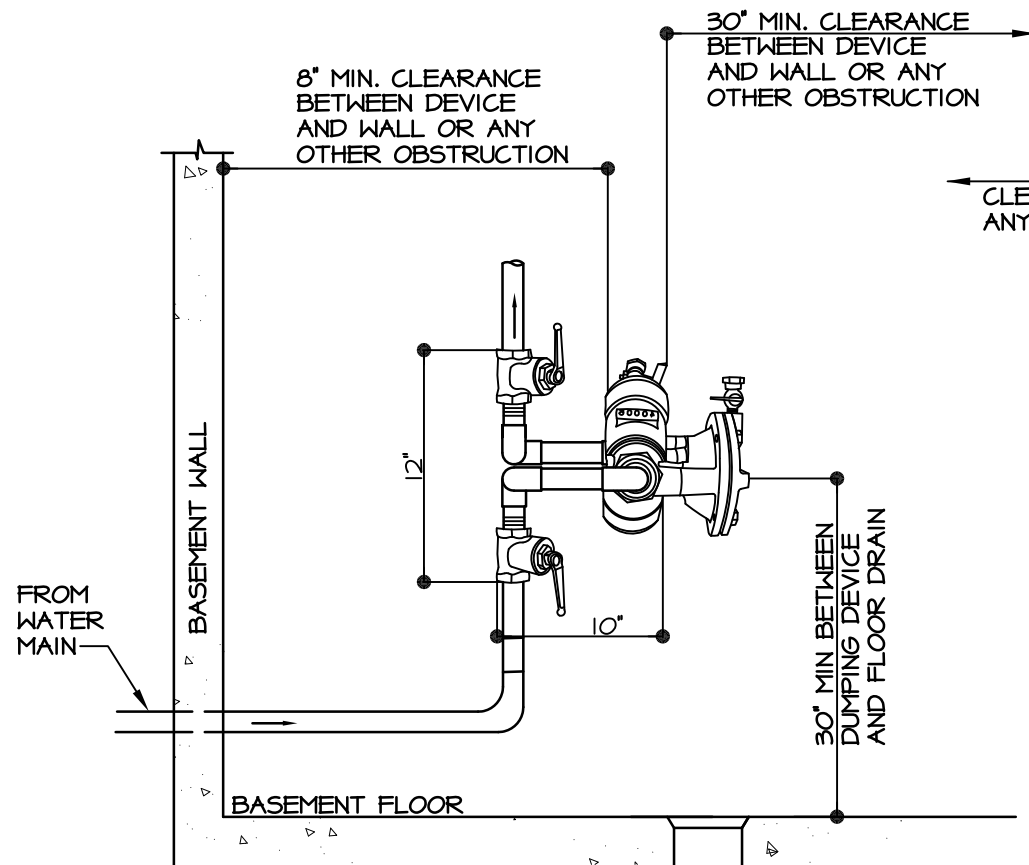

ON ALL NEW SERVICES, THE SIZE OF THE INCOMING PIPING SHALL EQUAL THE SIZE OF METER.

FLOOR DRAIN WITH GRAVITY PREFERRED \* DISCHARGE MUST BE VISIBLE AT OUTFILL

**ELEVATION**  
NO SCALE

\* IF A FLOOR DRAIN WITH GRAVITY DISCHARGE IS NOT FEASIBLE, MAINTAIN 48" CLEARANCE OFF BASEMENT FLOOR AND MINIMUM BASEMENT FLOOR AREA OF 1000 SQUARE FEET.

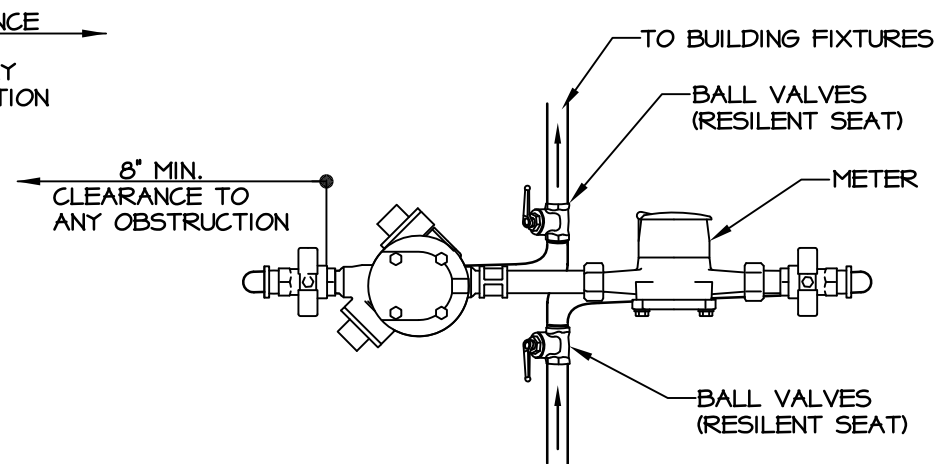

**FRONT VIEW**  
NO SCALE

**NOTIFICATION TO WATER DISTRICT:**

THE PLUMBER SHALL NOTIFY THE SUPERINTENDENT OF THE SOUTH FARMINGDALE WATER DISTRICT AT (516) 249-3330 A MINIMUM OF 24 HOURS PRIOR TO THE COMMENCEMENT OF ANY WORK.

**NOTES:**

1. ALL CONNECTIONS ON THE DOMESTIC WATER SERVICE SHALL BE DOWNSTREAM FROM THE REDUCED PRESSURE ZONE DEVICE ASSEMBLY. BYPASSING OF A BACKFLOW PREVENTION DEVICE IS A VIOLATION OF NEW YORK STATE HEALTH DEPARTMENT RULES AND REGULATIONS.
2. ALL INSTALLATIONS SHALL BE IN ACCORDANCE WITH ALL APPLICABLE NASSAU COUNTY AND NEW YORK STATE HEALTH DEPARTMENT REQUIREMENTS.
3. IT IS THE OWNER'S RESPONSIBILITY TO TEST ALL BACKFLOW PREVENTION DEVICES AT LEAST ANNUALLY WITH RESULTS REPORTED TO THE SOUTH FARMINGDALE WATER DISTRICT AND NASSAU COUNTY HEALTH DEPARTMENT ON NEW YORK STATE FORM GEN 215.
4. RPZ DEVICE MUST NOT BE SUBJECTED TO FLOODING OR FREEZING.
5. WATER METERS, SETTERS AND RPZ DEVICE MUST BE PURCHASED FROM THE DISTRICT.
6. SOUTH FARMINGDALE WATER DISTRICT HAS STANDARIZED ON FEBCO 825Y.
7. THE PLUMBER SHALL BE LICENSED BY THE TOWN OF OYSTER BAY AND SHALL BE APPROVED BY THE SOUTH FARMINGDALE WATER DISTRICT.
8. SHUT OFF VALVES ON RPZ DEVICE MUST BE RESILIENT SEAT AND BE BY THE SAME MANUFACTURER AS DEVICE.

**SPECIAL NOTE:**

IT IS SOLELY THE RESPONSIBILITY OF THE PROPERTY OWNER TO INSURE AGAINST THE POTENTIAL FREEZING OF ANY RPZ DISCHARGE. THE PROPERTY OWNER SHALL HOLD HARMLESS. THE SOUTH FARMINGDALE WATER DISTRICT FROM ANY CLAIMS ARISING DUE TO DAMAGE OR INJURIES CAUSED BY ANY RPZ DISCHARGE.

**SOUTH FARMINGDALE  
WATER DISTRICT**  
**1" REDUCED PRESSURE ZONE  
DEVICE WITH METER INSIDE**

STANDARD DETAIL  
**BASEMENT INSTALLATION**  
(EXISTING OR NEW SERVICE)

APPROVED BY THE BOARD OF COMMISSIONERS

APPROVED BY: \_\_\_\_\_ DATE: \_\_\_\_\_